

SERPENTIX

The world's most versatile conveyor system



The Serpentix System offers versatility and features not available with an ordinary conveyor system.

The pictures you are about to study show how Serpentix is being used today in twenty-one different applications. It is the most versatile conveyor system ever developed. Serpentix will adapt to any situation where the need is to move materials quickly, efficiently, and at low cost.

Imagine a conveyor system as flexible as your watch band . . . twisting around corners, climbing angles as steep as 90 degrees, turning back on itself in a surprisingly small radius. Think of it carrying material as fragile as mail or

clothing; or as rugged and abrasive as quarried rock or cement. It can discharge cargo without slowing down and then, righting itself, return not empty but with another load.

Serpentix is truly the world's most versatile materials handling system. Now in use on five continents at over 600 installations.

See for yourself how the unique Serpentix System, illustrated on the pages that follow, can solve your most difficult material transportation problem.

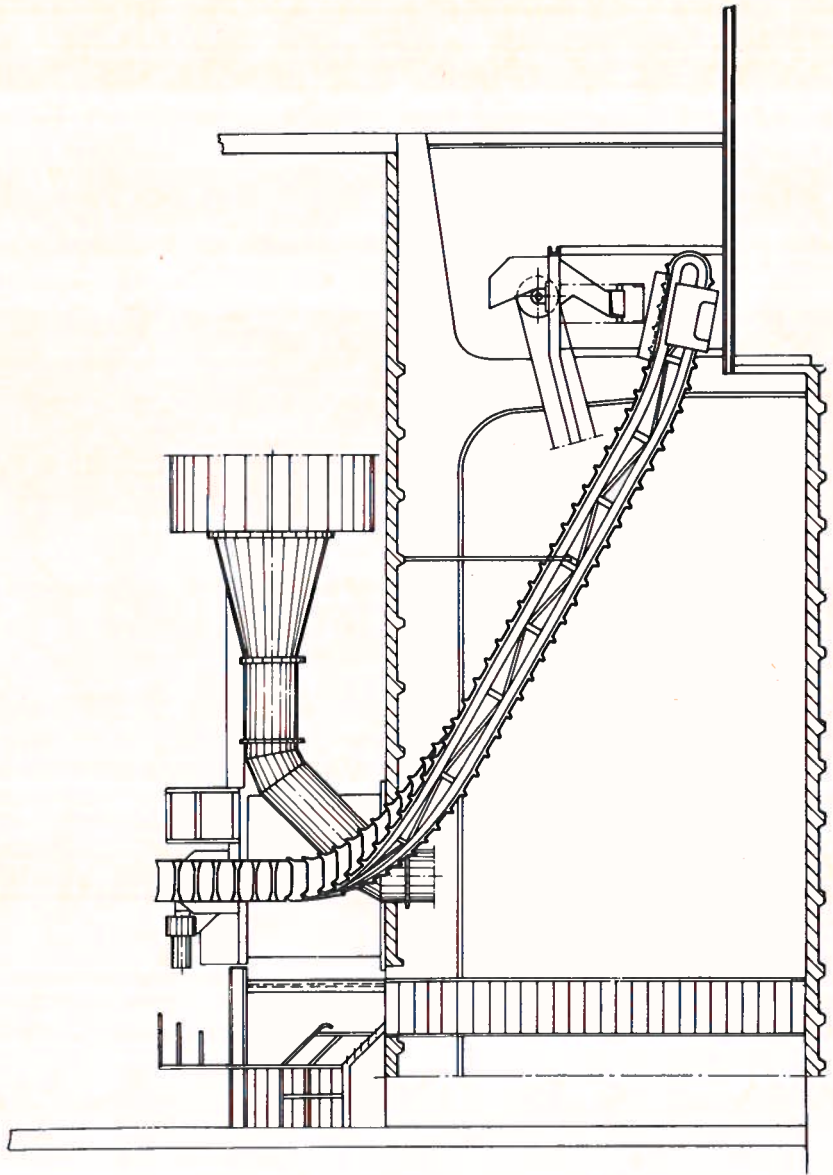

Iron Ore Smelter
 Belt Width:
 Center Distance:
 Material Transported:
 Lump Size:
 Belt Speed:
 Capacity:
 Angle of Incline:
 Horsepower:
 Height Elevated:
 Installed:

26"
 56'
 Iron Ore
 - 1 1/2"
 90 TPH
 160 FPM
 30.8°
 5
 26'
 February 1962

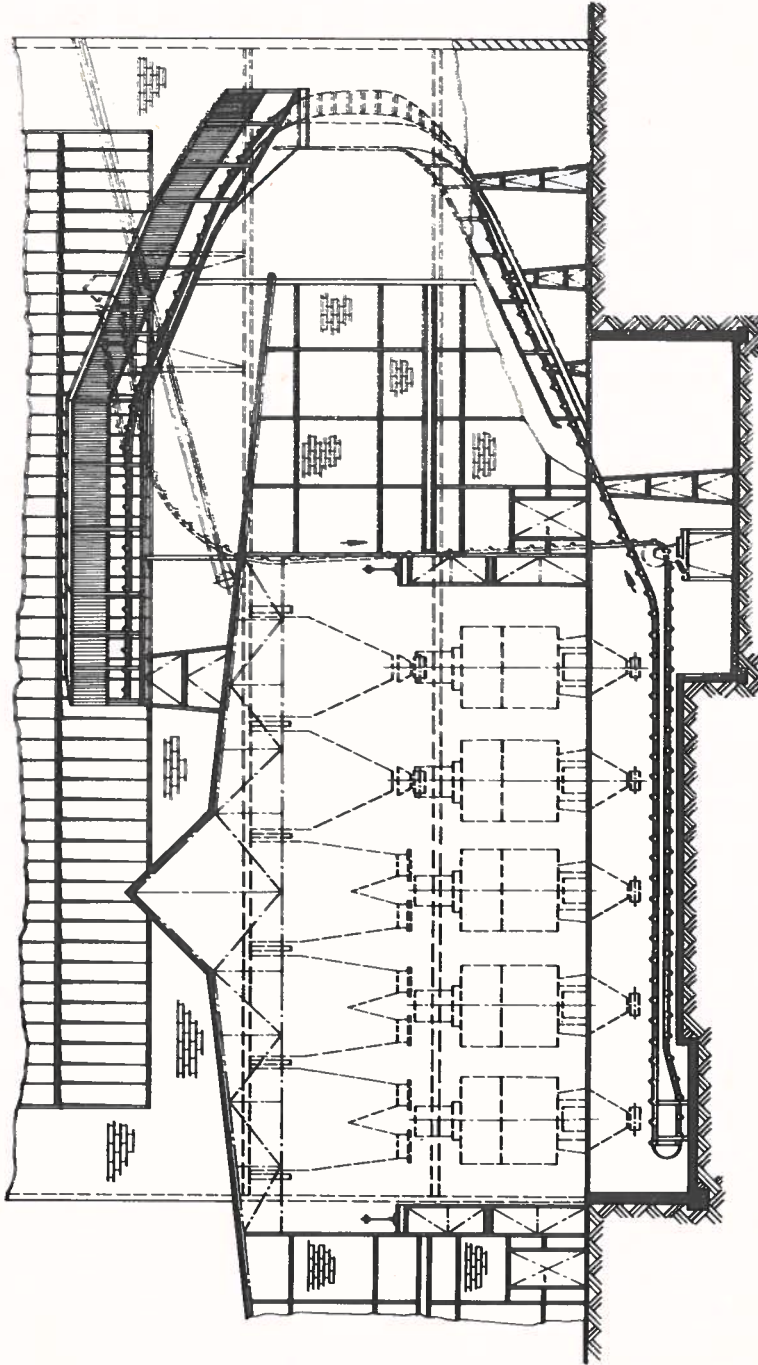

Schematic Plan

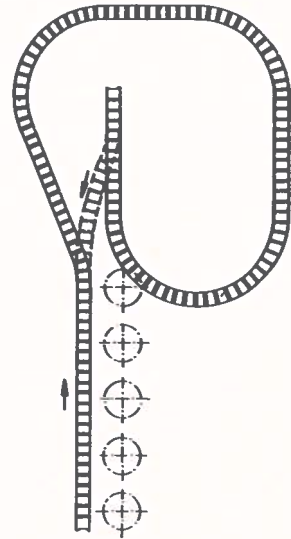

A Steel Plant

Belt Width: 32"
 Belt Length: 415'
 Material Transported: Molding Sand
 Material Size: -.06"
 Capacity: 237 TPH
 Belt Speed: 205 FPM
 Angle of Incline: 23.3°
 Horsepower: 40
 Height Elevated: 50'
 Installed: December 1962

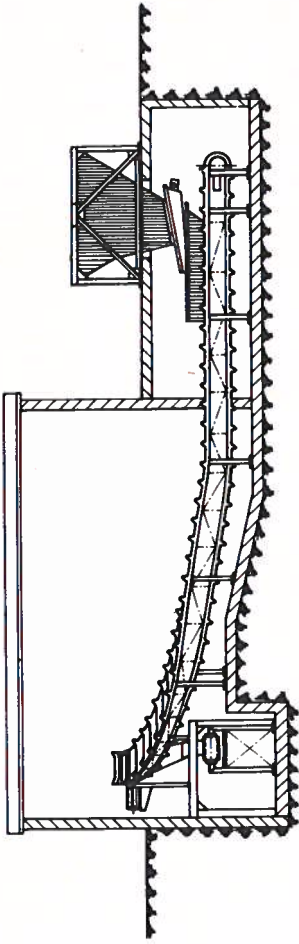

A Power Plant
 Belt Width: 32"
 Center Distance: 66'
 Material Transported: Fine Coal
 Material Size: -0.4"
 Capacity: 150 TPH
 Belt Speed: 190 FPM
 Angle of Incline: 15.5°
 Horsepower: 7.5
 Height Elevated: 8'
 Installed: July 1963

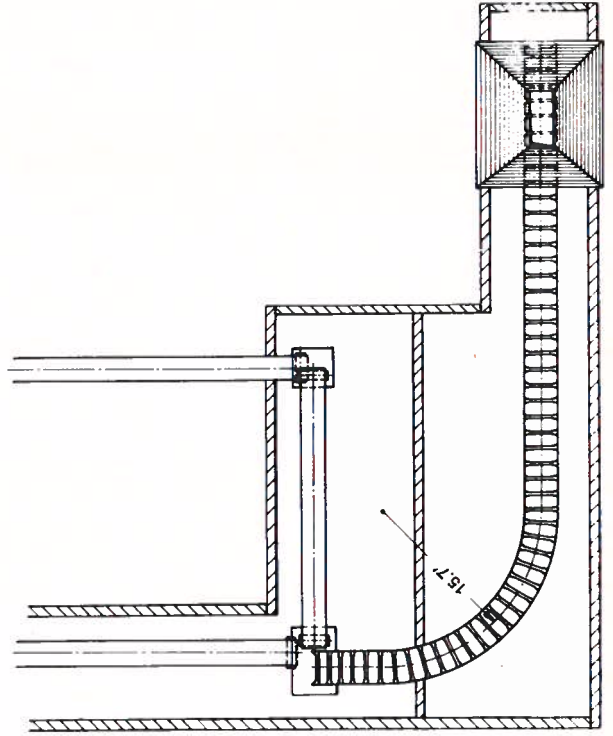

A Limestone Plant

Belt Width: 26"
Center Distance: 128'
Material Transported: Fire Clay
Material Size: -6"
Capacity: 93 TPH
Belt Speed: 177 FPM
Angle of Incline: 28°
Horsepower: 15
Height Elevated: 58'
Installed: September 1962

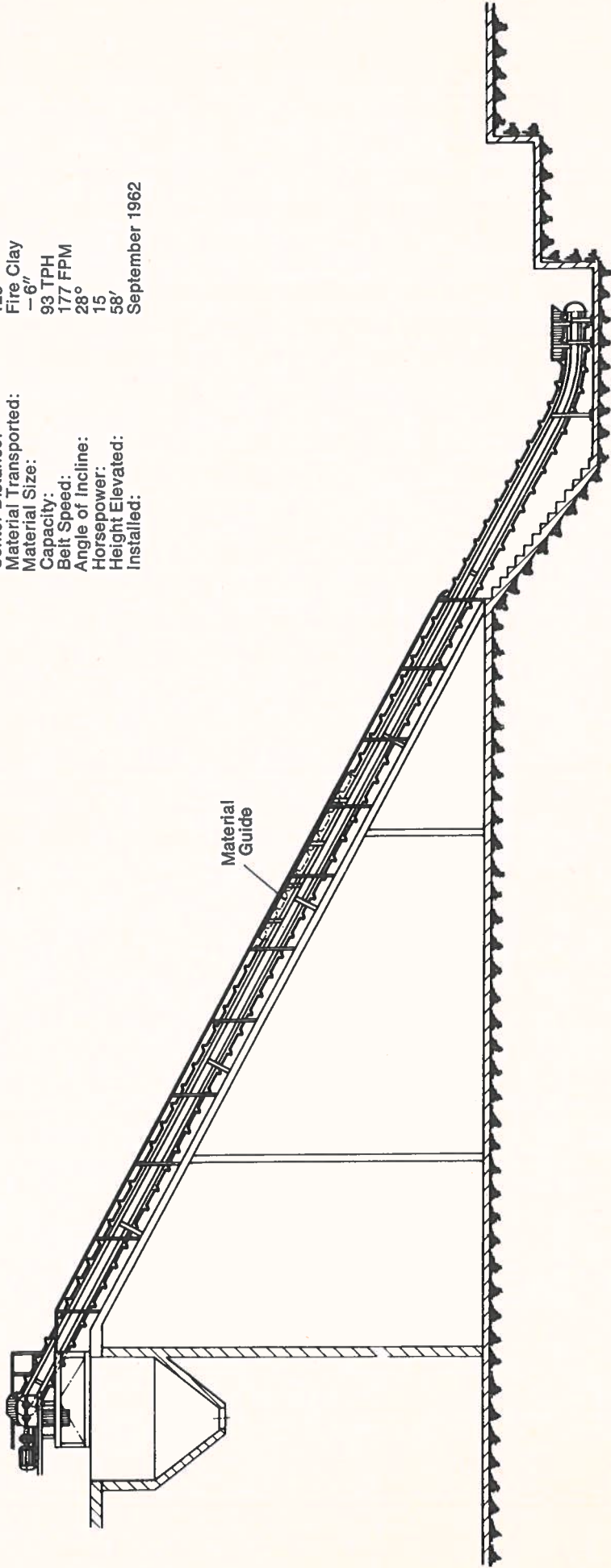

Combined Drive/Tension Station

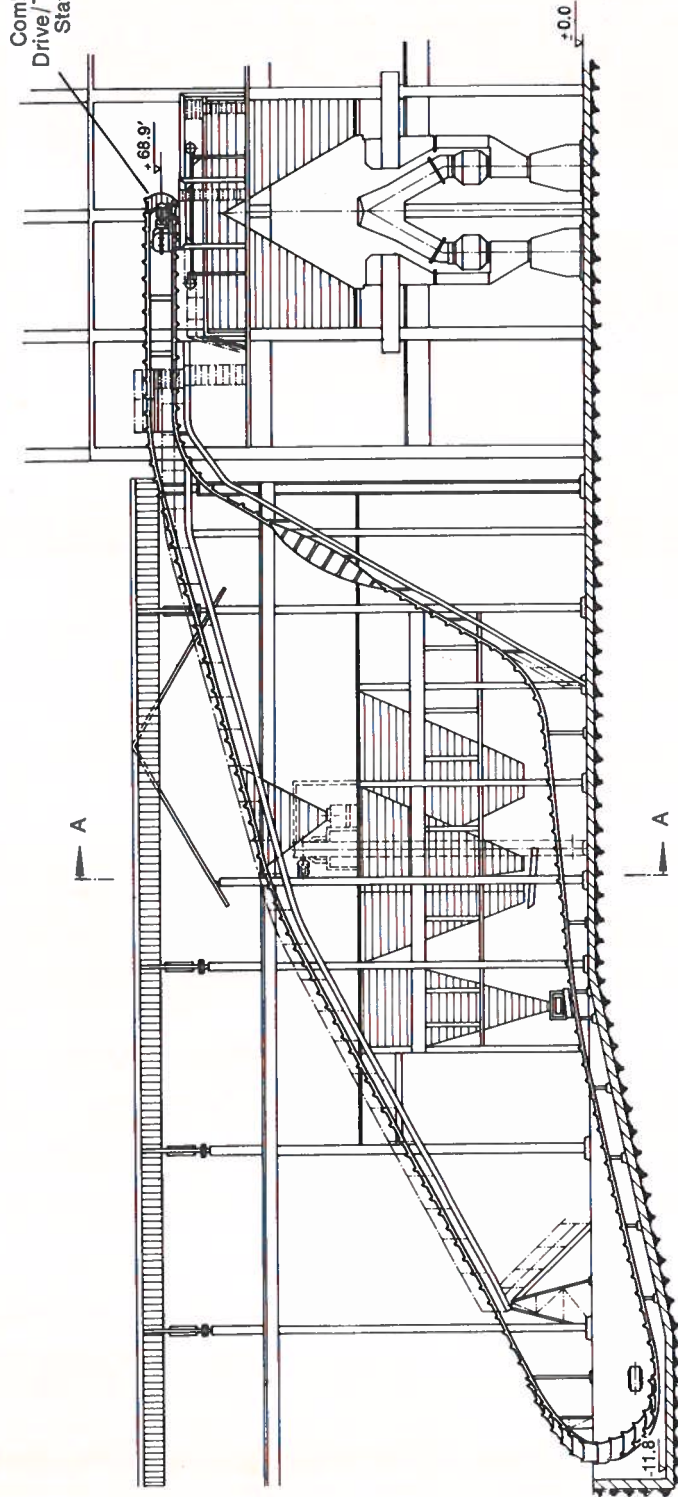

Side Discharge

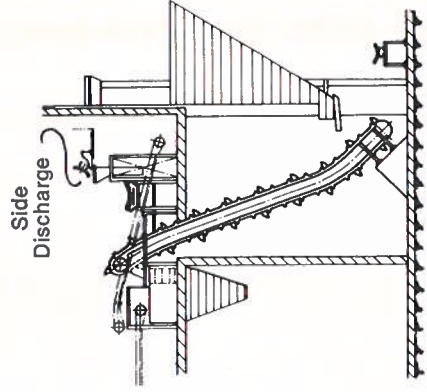

Sec. A-A

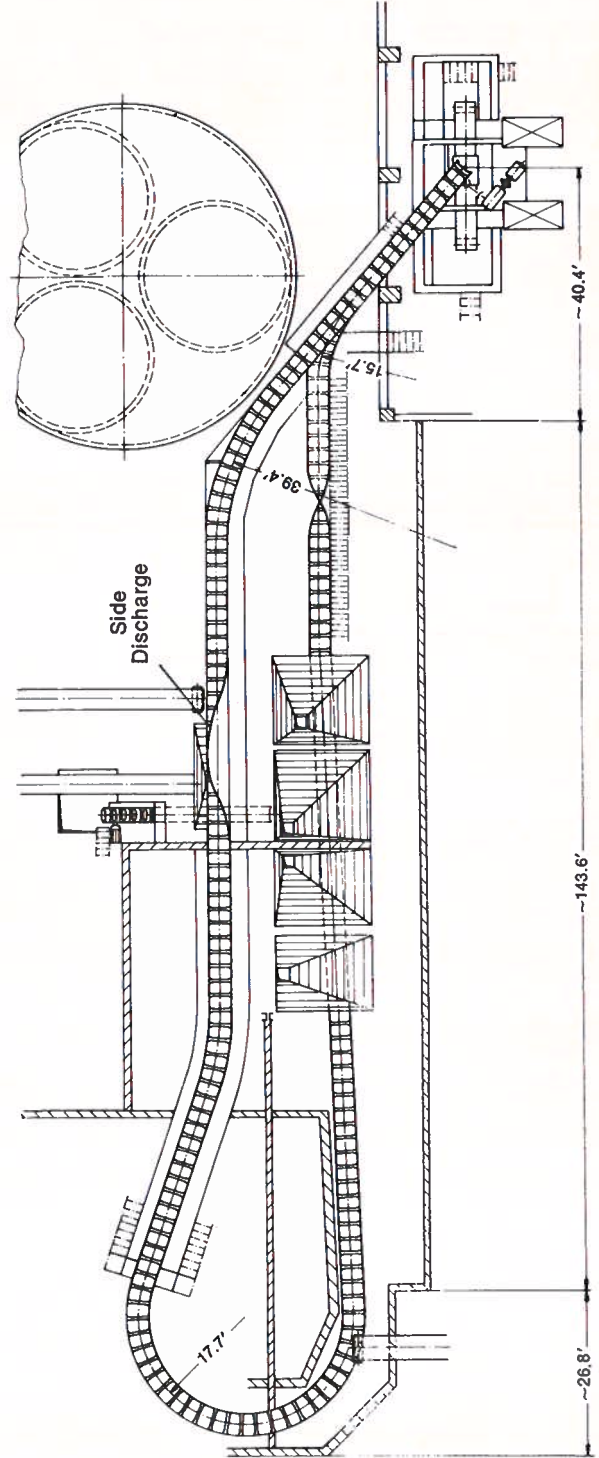

Two Conveyors in a Large Cement Plant

- Belt Width: 32"
- Belt Length: 415'
- Material Transported: Limestone and Slag
- Capacity: 200 TPH
- Belt Speed: 200 FPM
- Angle of Incline: 27°
- Horsepower: 50
- Height Elevated: 65'
- Installed: December 1962

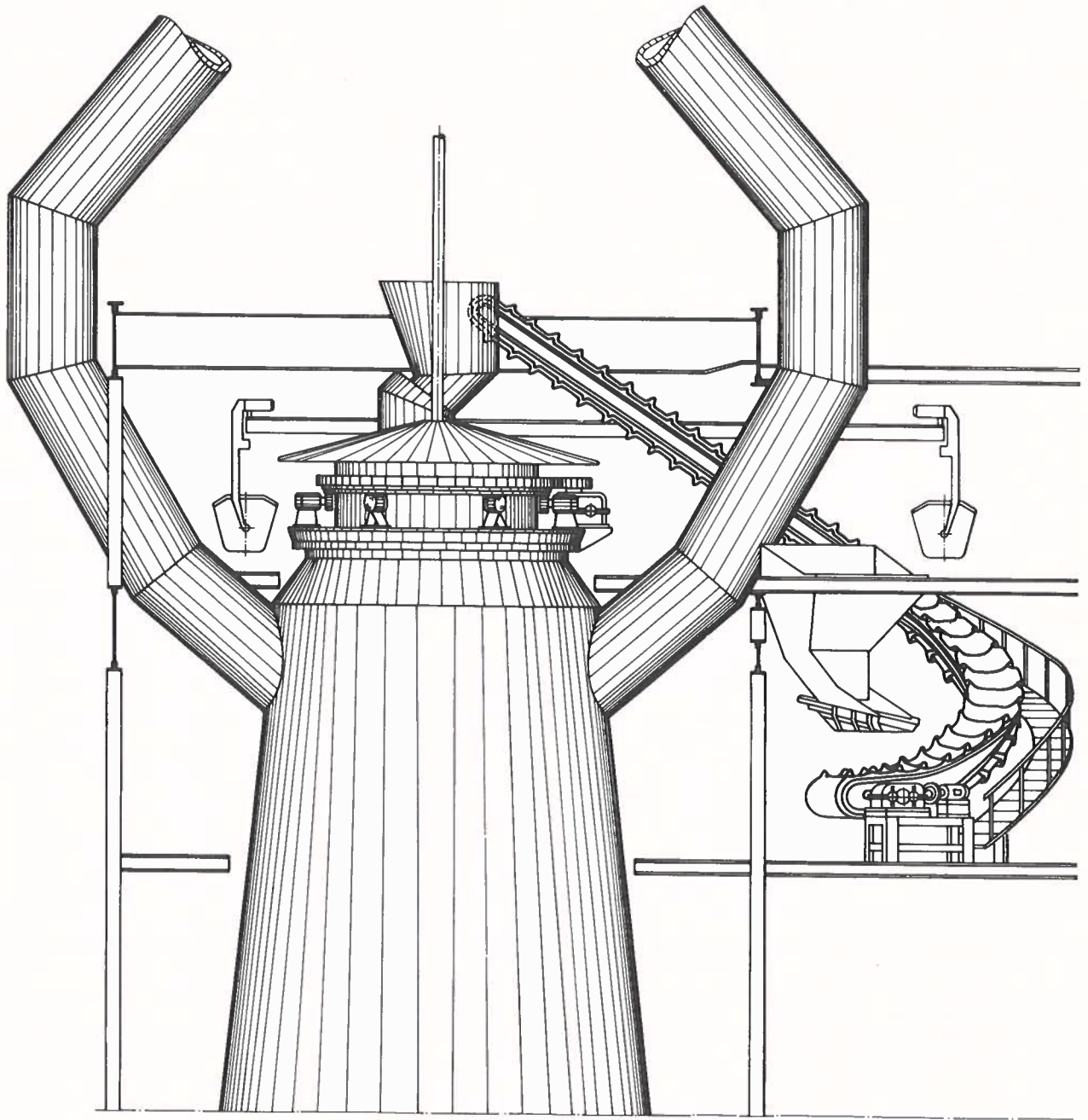

Blast Furnace Charging Conveyor

Belt Width: 40"
 Center Distance: 120'
 Material Transported: Iron Ore and Fluxes
 Material Size: -8"
 Capacity: 300 TPH

Belt Speed: 160 FPM
 Helix Angle: 33.5°
 Horsepower: 15
 Height Elevated: 25'
 Installed: October 1961

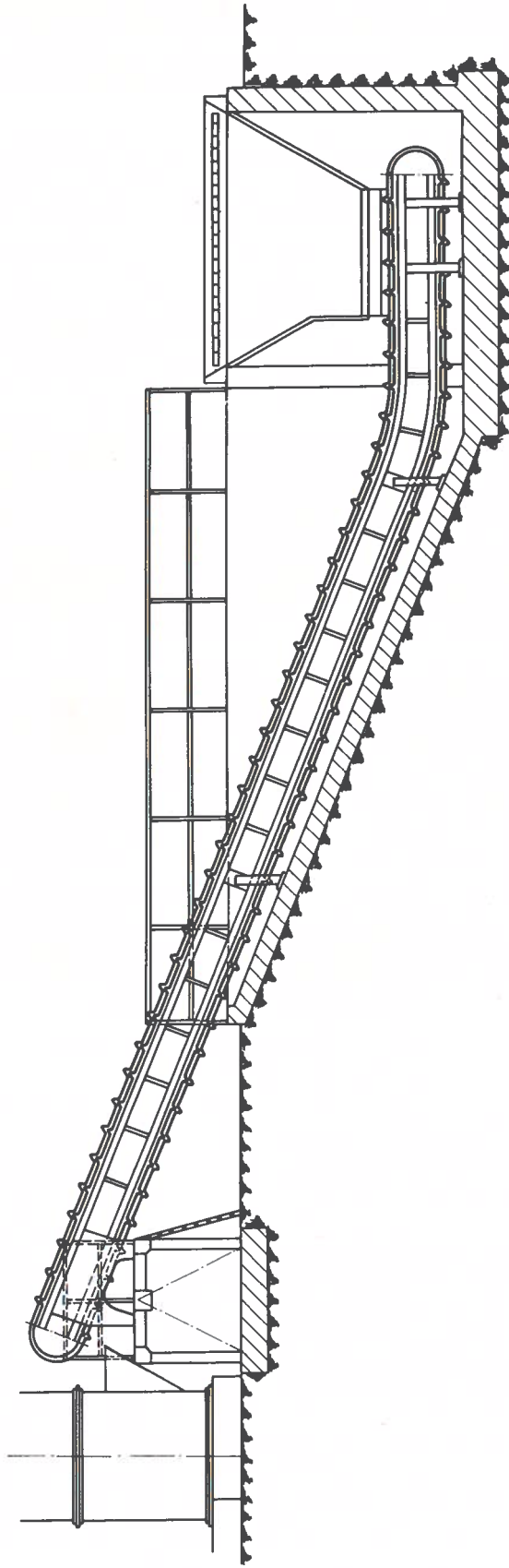

A Cement Plant

Belt Width: 26"
 Center Distance: 56'
 Material Transported: Various Sands
 Material Size: - 0.8"
 Capacity: 80 TPH
 Belt Speed: 79 FPM
 Angle of Incline: 21°
 Horsepower: 7.5
 Height Elevated: 16'
 Installed: March 1963

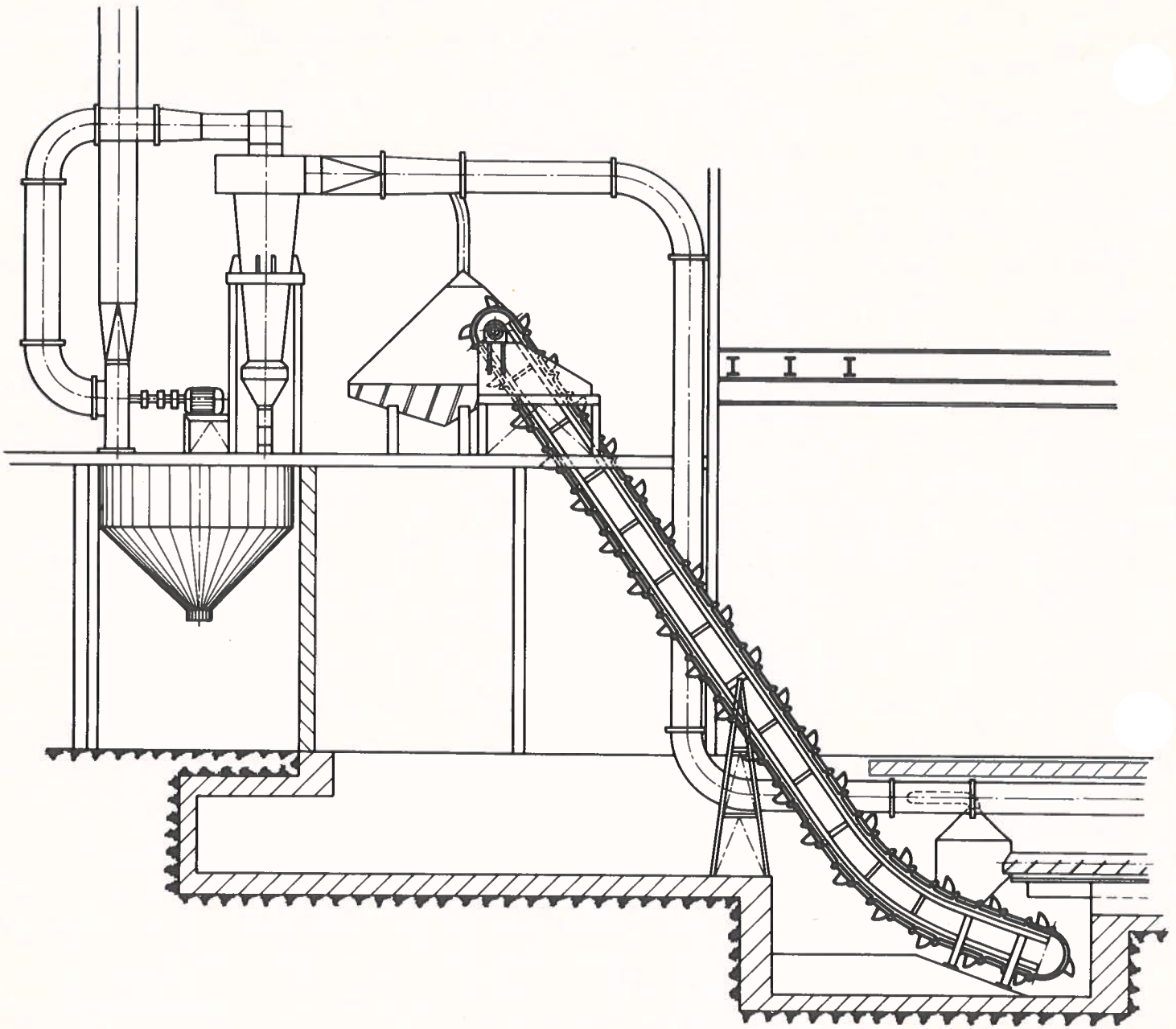

A Steel Plant

Belt Width:	26"
Center Distance:	45'
Material Transported:	Shakeout Sand
Material Size:	- 4"
Capacity:	30 TPH
Belt Speed:	157 FPM
Angle of Incline:	55°
Horsepower:	4
Height Elevated:	32'
Installed:	April 1963

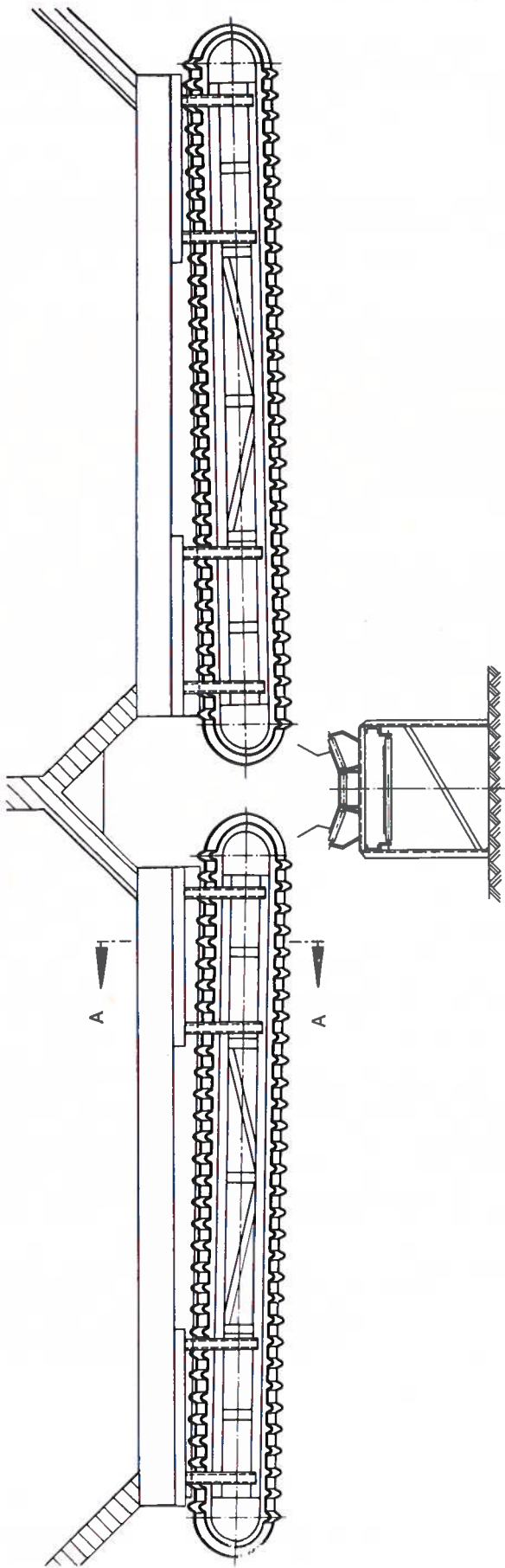

Two Feeder Conveyors in a Cement Plant
 Belt Width: 26"
 Center Distance: 20'
 Material Transported: Limestone
 Material Size: -1"
 Capacity: 45 TPH
 Belt Speed: Up to 20 FPM
 Horsepower: 5
 Installed: September 1961

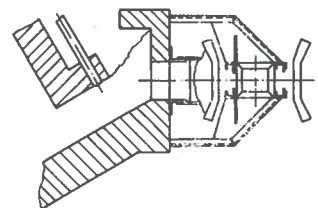

Sec. A-A

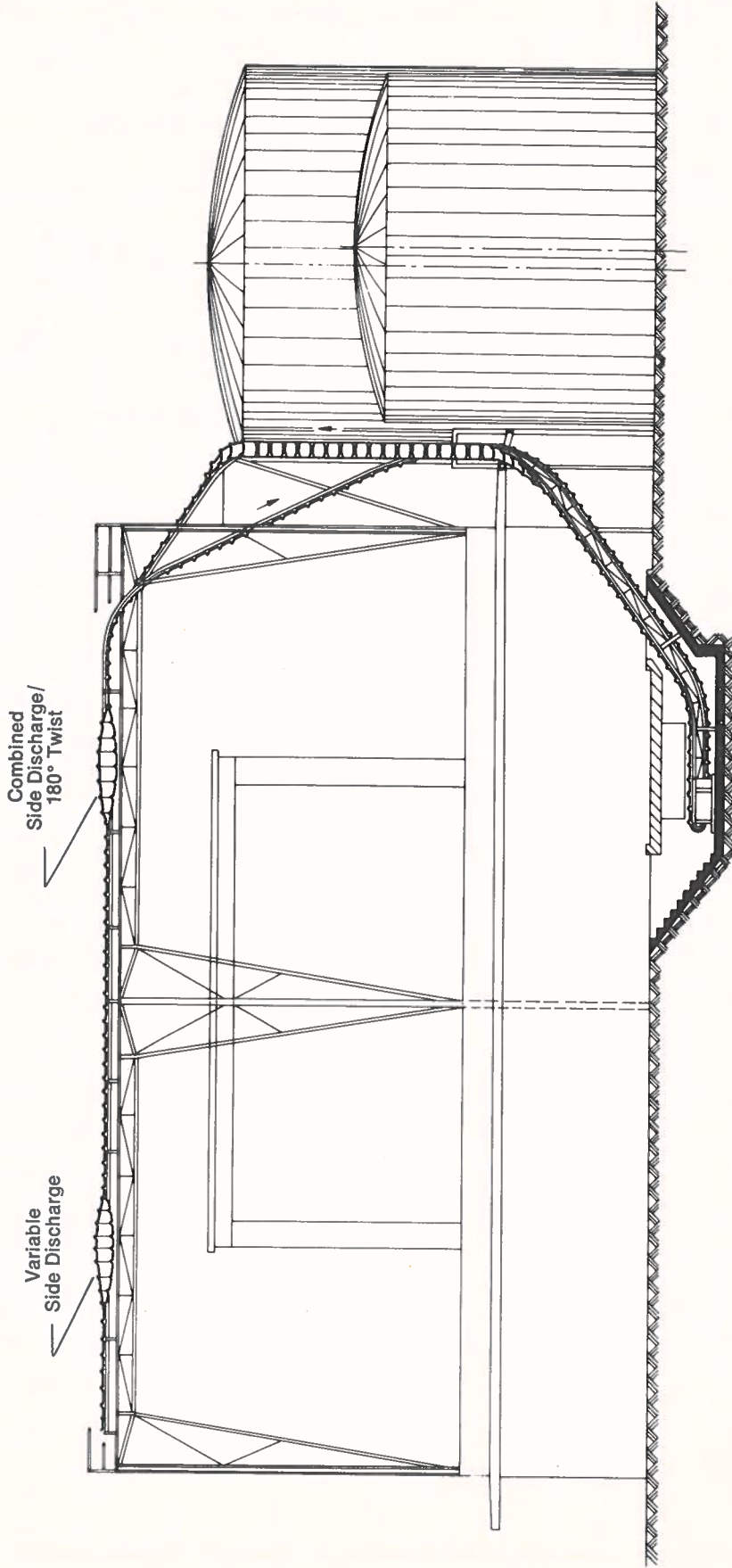

Schematic
Plan View



A Chemical Plant

- Belt Width: 26"
- Belt Length: 475'
- Material Transported: Halite
- Material Size: -8"
- Capacity: 50 TPH
- Belt Speed: 197 FPM
- Angle of Incline: 35.3°
- Horsepower: 15
- Height Elevated: 70'
- Installed: January 1962

A Lime and Cement Plant

Belt Width: 26"
Center Distance: 77'
Material: Limestone
Material Size: - 2"
Capacity: 38 TPH
Belt Speed: 143 FPM
Angle of Incline: 75°
Horsepower: 75
Height Elevated: 65'
Installed: November 1962

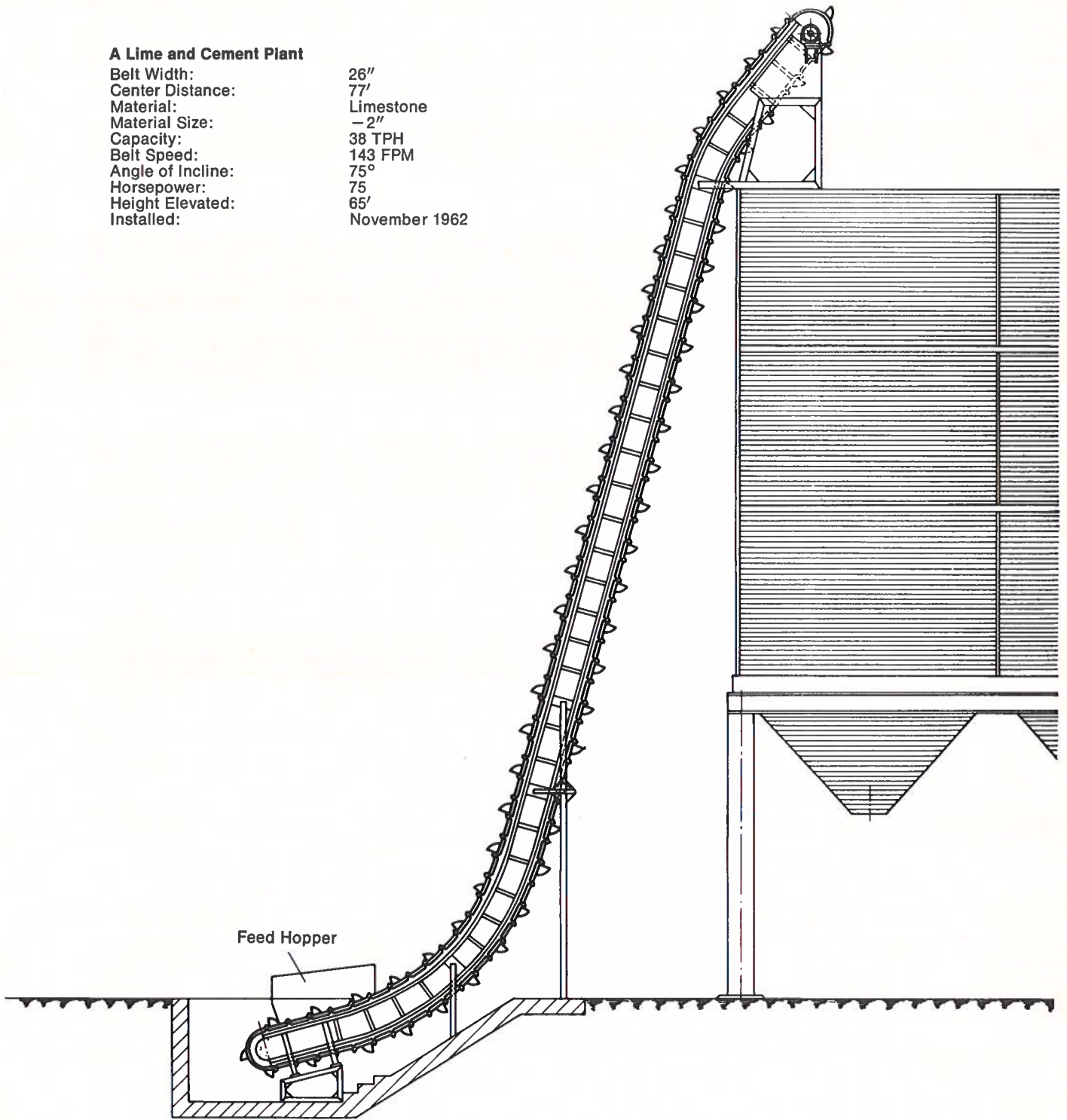

A Sugar Plant

Belt Width: 26"
Center Distance: 60'
Material Transported: Coke and Limestone
Material Size: -7"
Capacity: 30 TPH
Belt Speed: 197 FPM
Angle of Incline: Up to 35°
Horsepower: 3.5
Height Elevated: 30'
Installed: November 1959

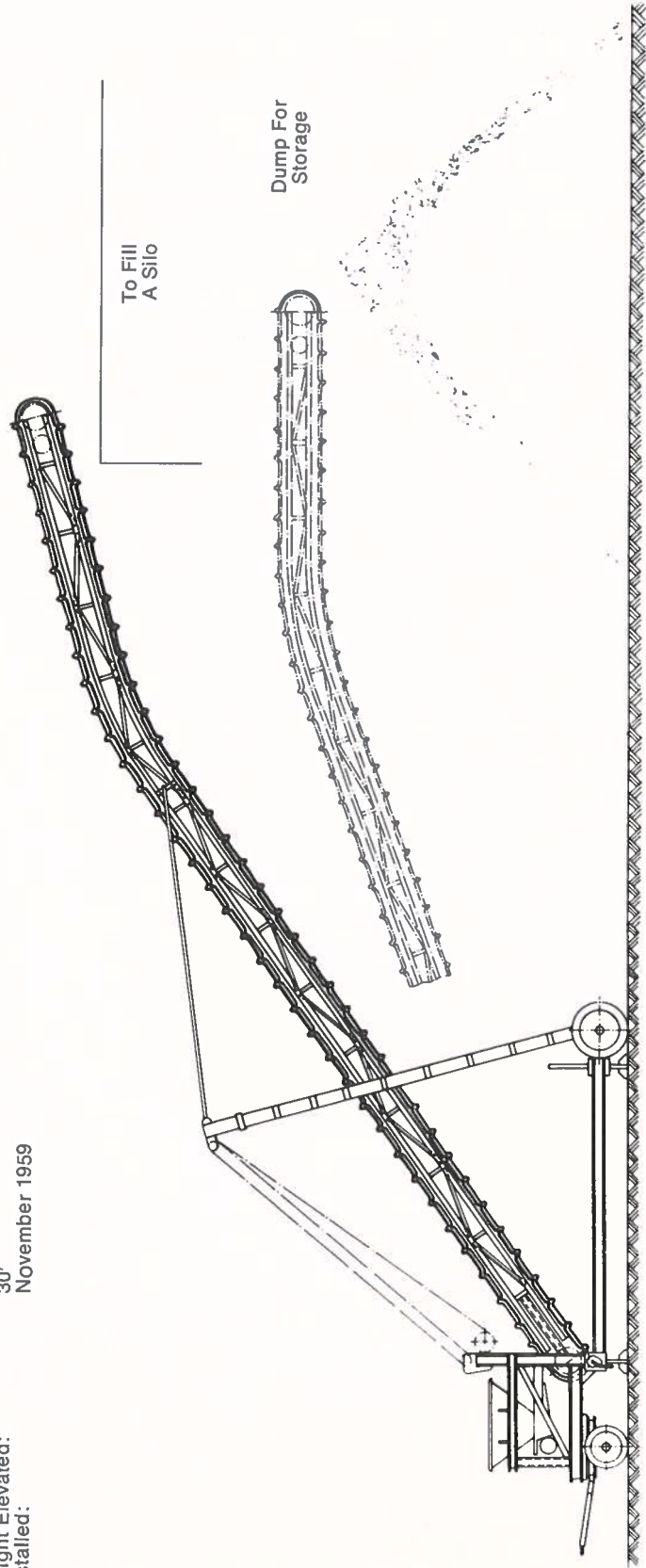

A Clay Plant

Belt Width:
Center Distance:
Material Transported:
Material Size:
Capacity:
Belt Speed:
Angle of Incline:
Horsepower:
Height Elevated:
Installed:

26"
93.5'
Moist Clay
- 1/2"
20 TPH
116 FPM
36°
5
33'
August 1963

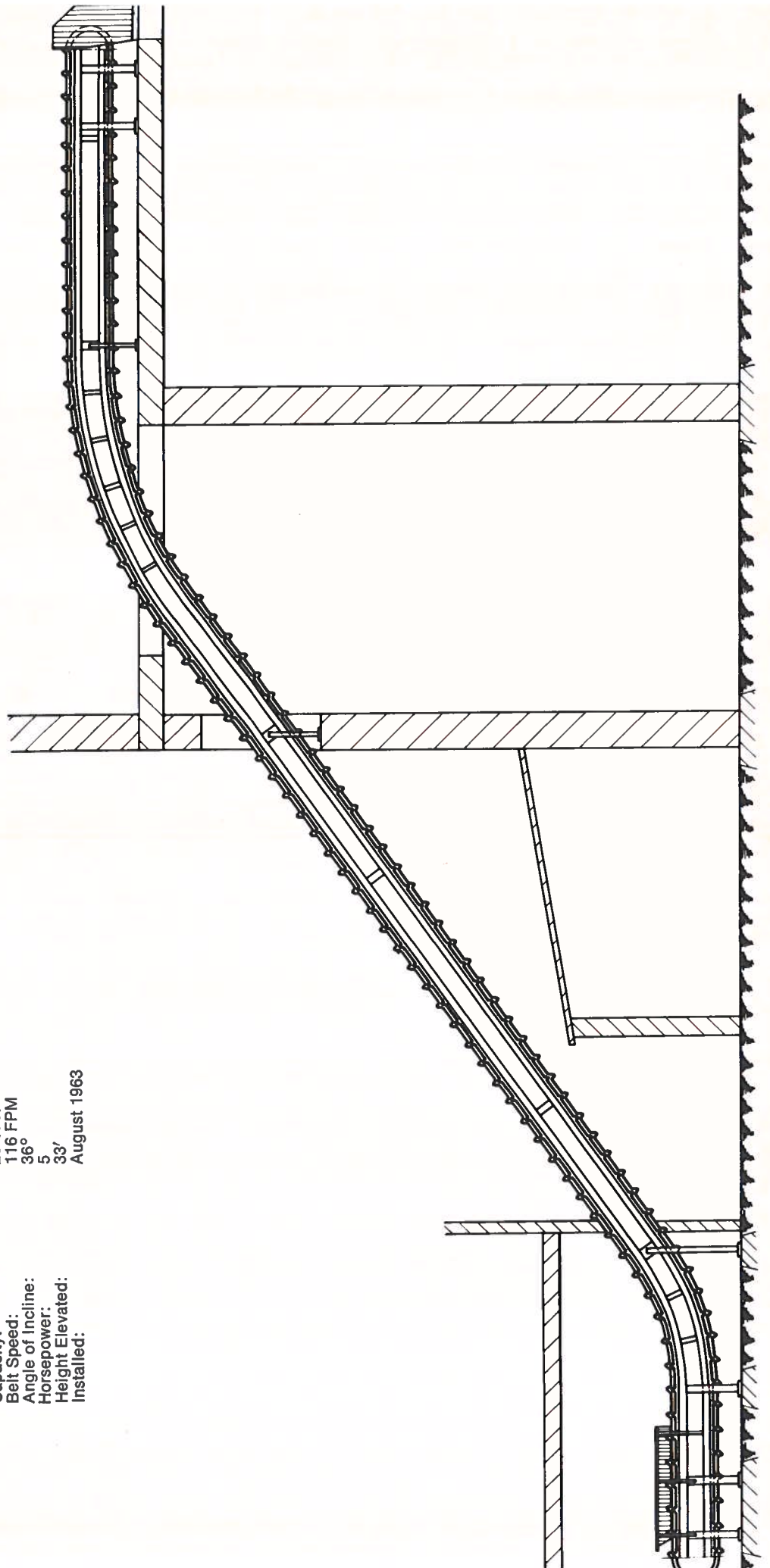

A Clay Plant

Belt Width: 26"
Center Distance: 63'
Material Transported: Clay
Material Size: -6"
Capacity: 25 TPH
Belt Speed: 118 FPM
Angle of Incline: 29°
Horsepower: 3
Height Elevated: 29'
Installed: February 1962

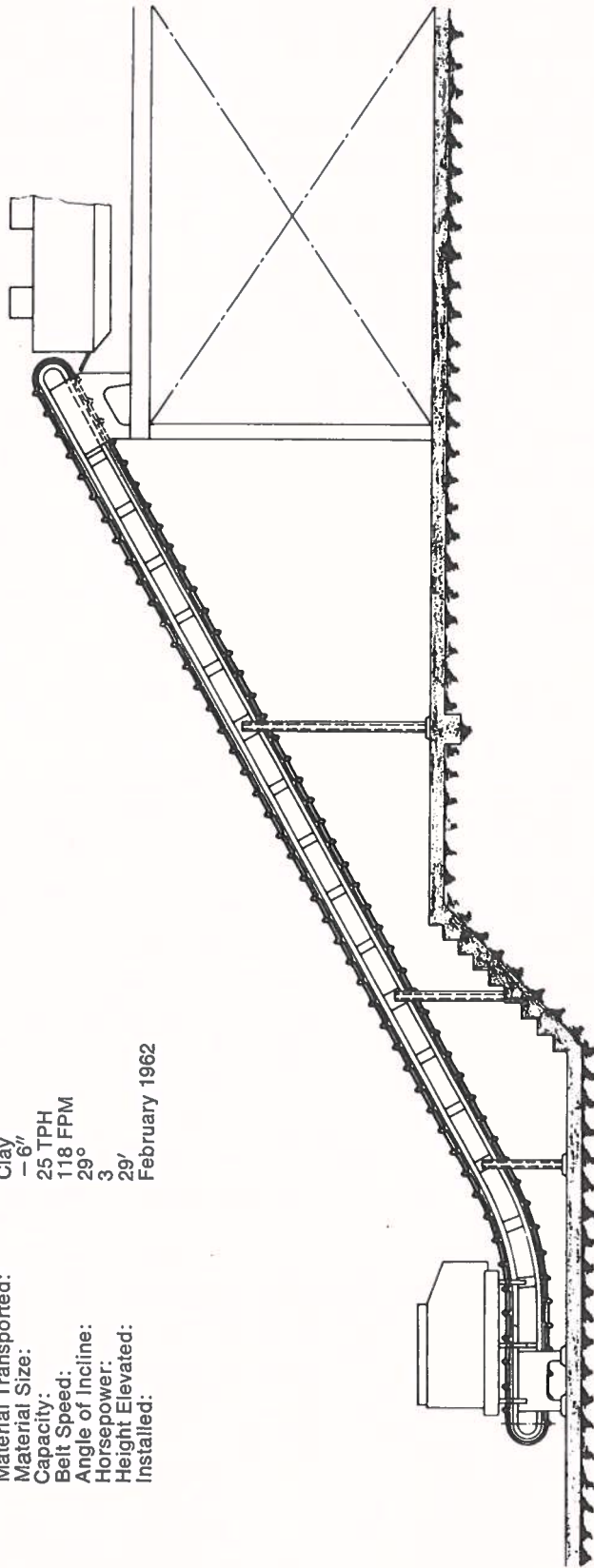

A Sugar Plant
 Belt Width: 26"
 Center Distance: 75'
 Material Transported: Coke and Limestone
 Material Size: - 3"
 Capacity: 50 TPH
 Belt Speed: 144 FPM
 Angle of Incline: 48°
 Horsepower: 7.5
 Height Elevated: 50'
 Installed: October 1962

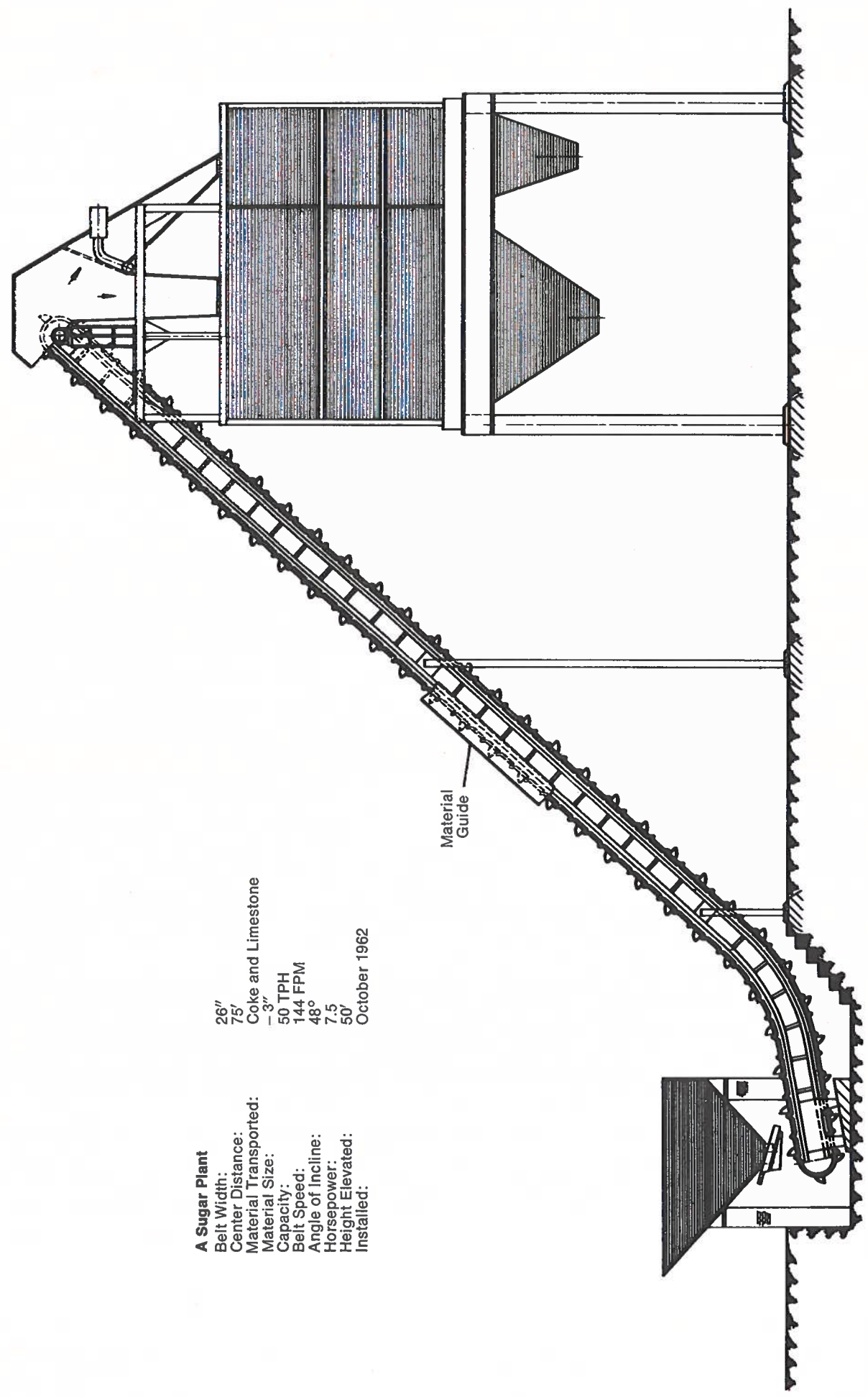

Material Guide

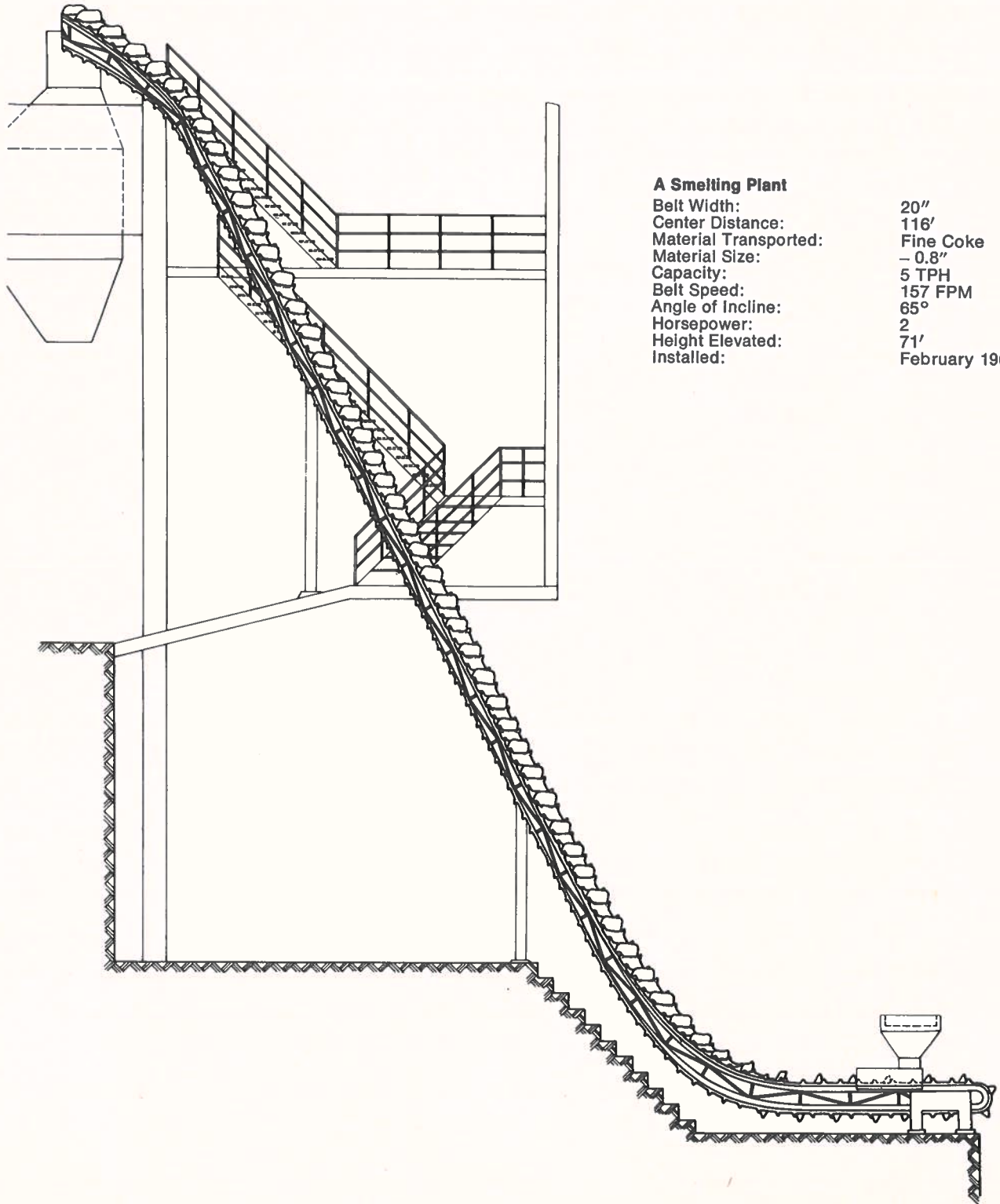

A Smelting Plant

Belt Width:	20"
Center Distance:	116'
Material Transported:	Fine Coke
Material Size:	- 0.8"
Capacity:	5 TPH
Belt Speed:	157 FPM
Angle of Incline:	65°
Horsepower:	2
Height Elevated:	71'
Installed:	February 1961

A Large Chemical Plant

Belt Width: 26"
Belt Length: 590'
Material Transported: Crude Sulphur
Material Size: -2"
Capacity: 25 TPH
Belt Speed: 153 FPM
Helix Angle: 18.3°
Horsepower: 20
Height Elevated: 877.5'
Installed: July 1962

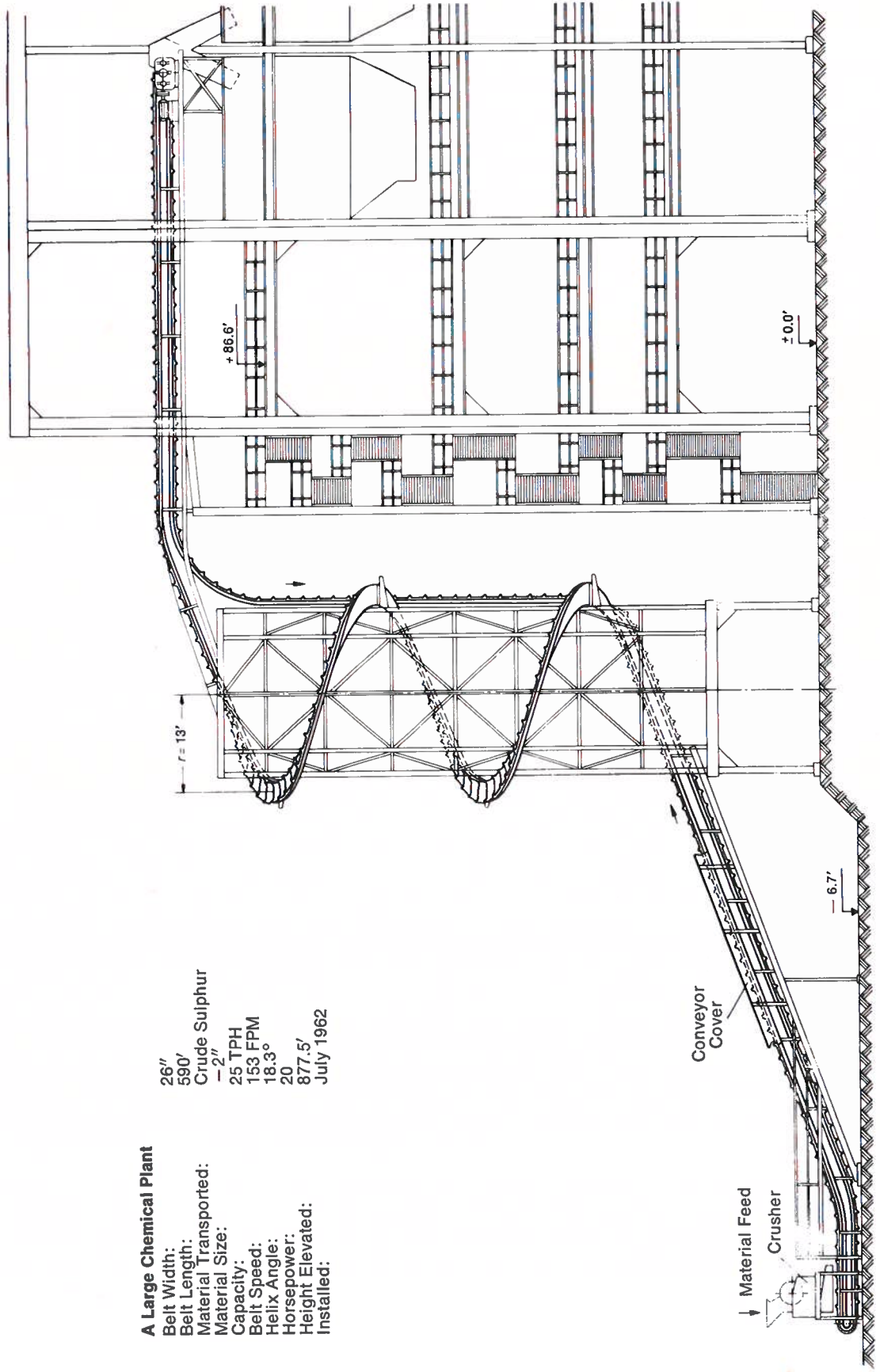

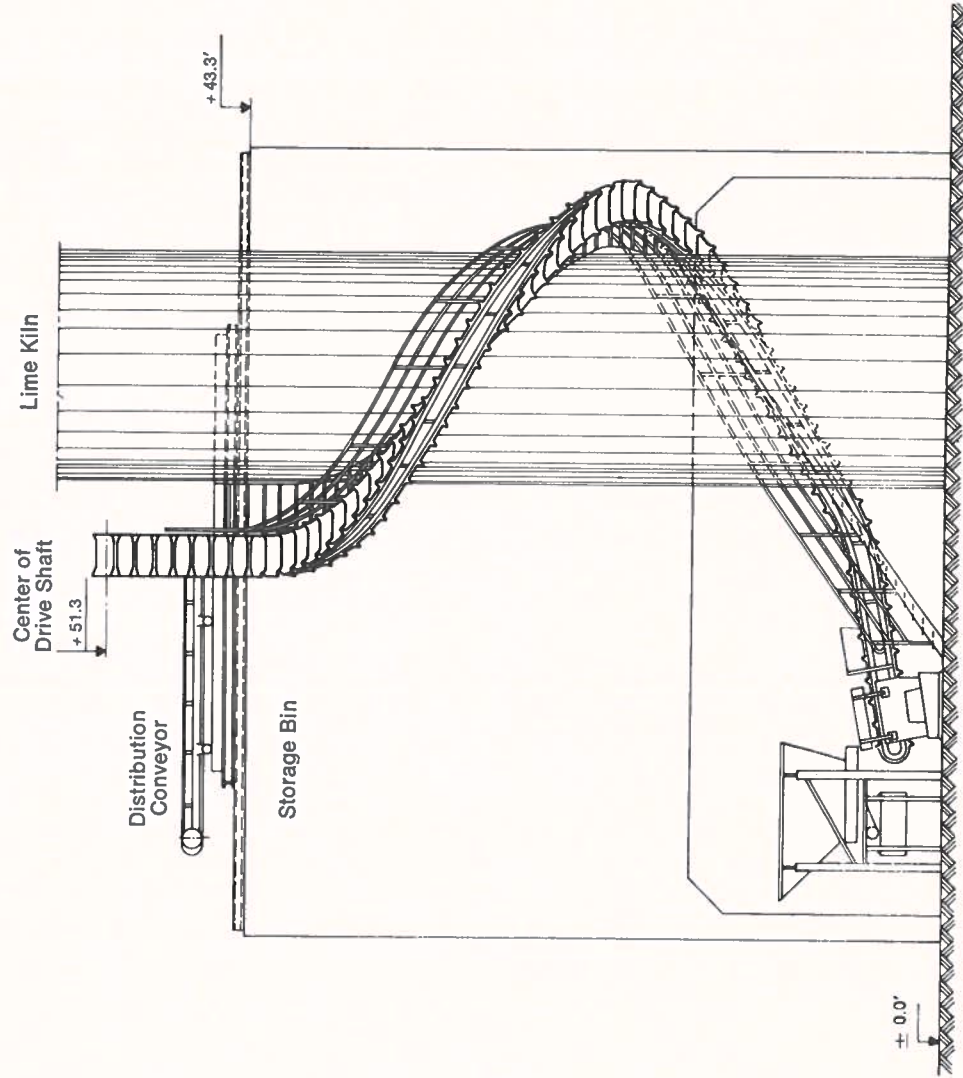

A Large Chemical Plant

Belt Width: 26"
 Center Distance: 105'
 Material Transported: Coke and Limestone
 Material Size: 7"
 Capacity: 60 TPH
 Belt Speed: 118 FPM
 Helix Angle: 28°
 Horsepower: 75
 Height Elevated: 41'
 Installed: May 1960

A Lime and Cement Plant

Belt Width: 26"
Center Distance: 110'
Material: Wet Clay
Material Size: -6"
Capacity: 130 TPH
Belt Speed: 197 FPM
Incline Angle: 29°
Horsepower: 15
Height Elevated: 50'
Installed: February 1962

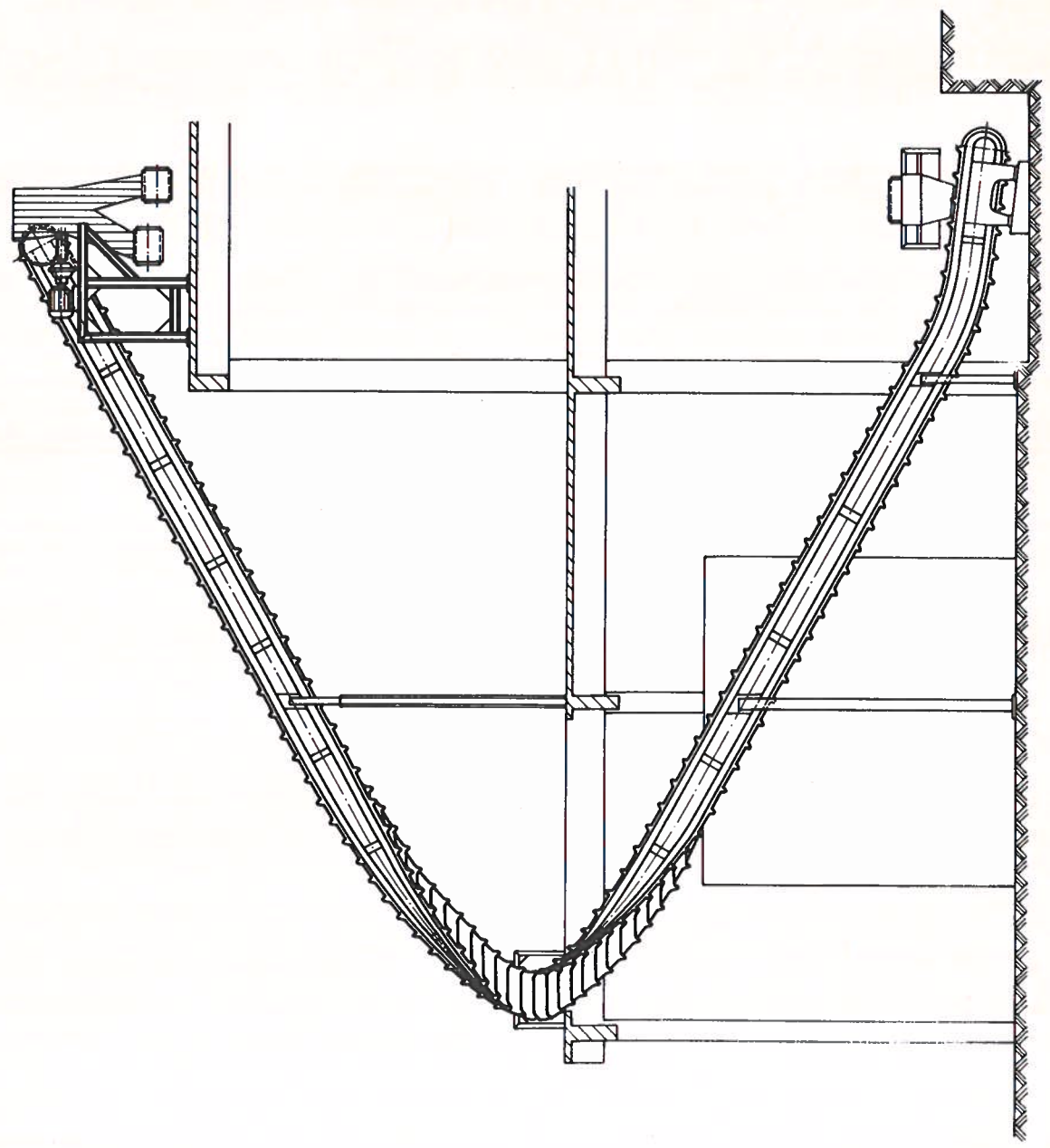

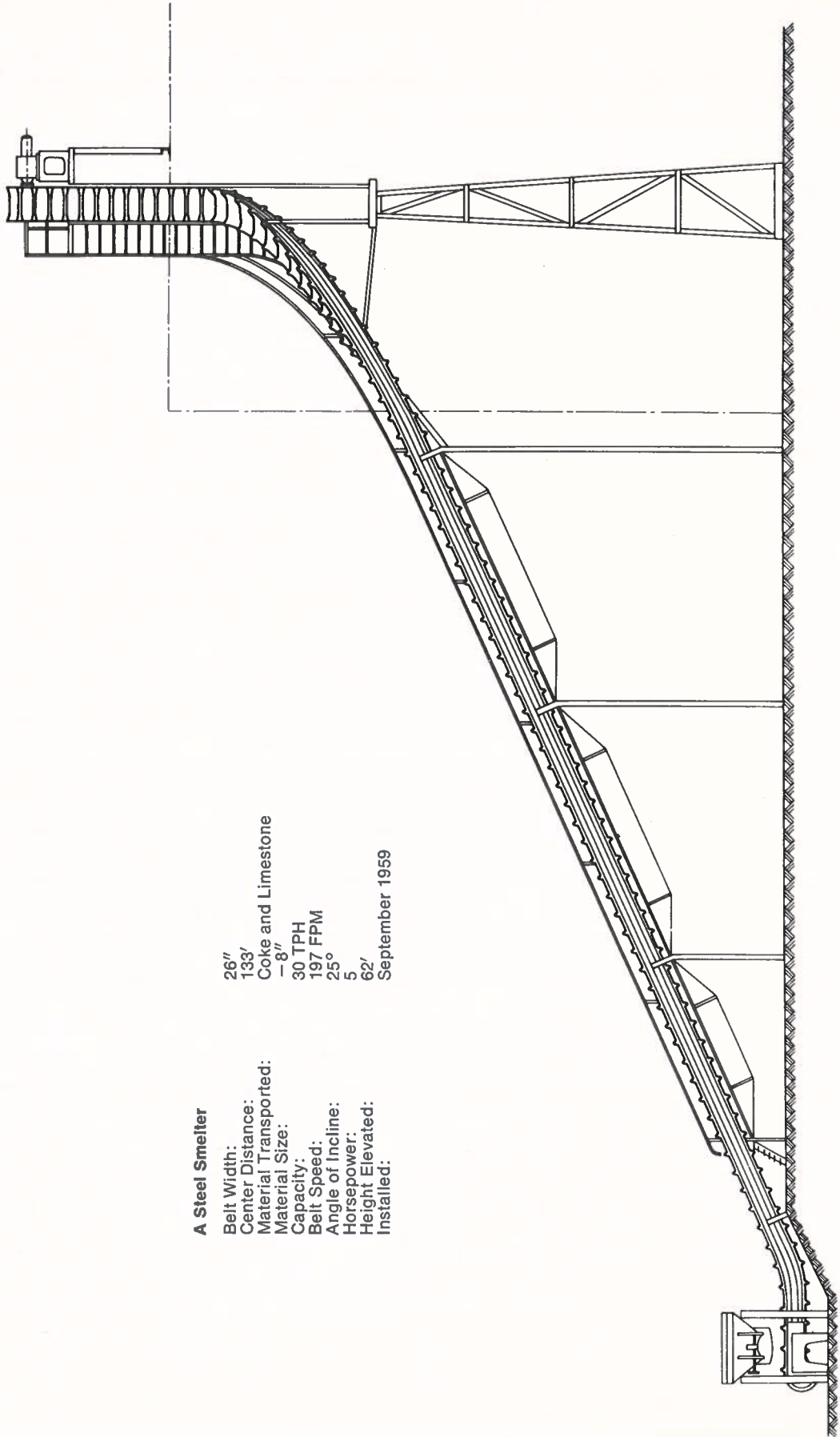

A Steel Smelter

Belt Width: 26"
 Center Distance: 133'
 Material Transported: Coke and Limestone
 Material Size: -8"
 Capacity: 30 TPH
 Belt Speed: 197 FPM
 Angle of Incline: 25°
 Horsepower: 5
 Height Elevated: 62'
 Installed: September 1959

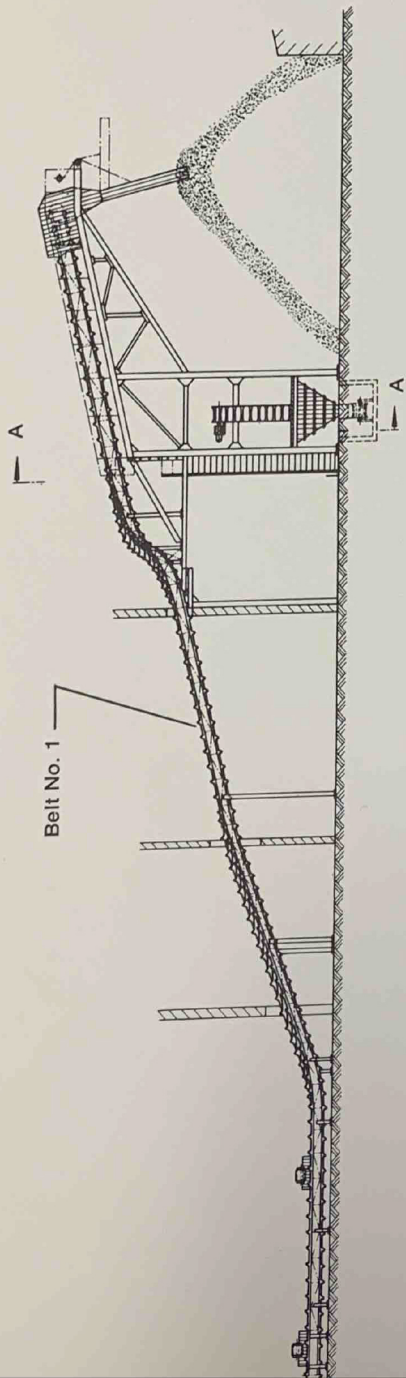

Belt No. 1

A

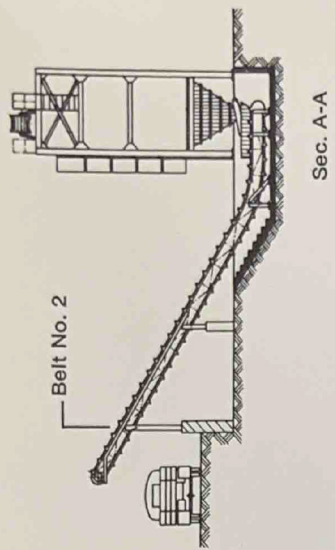

Belt No. 2

Sec. A-A

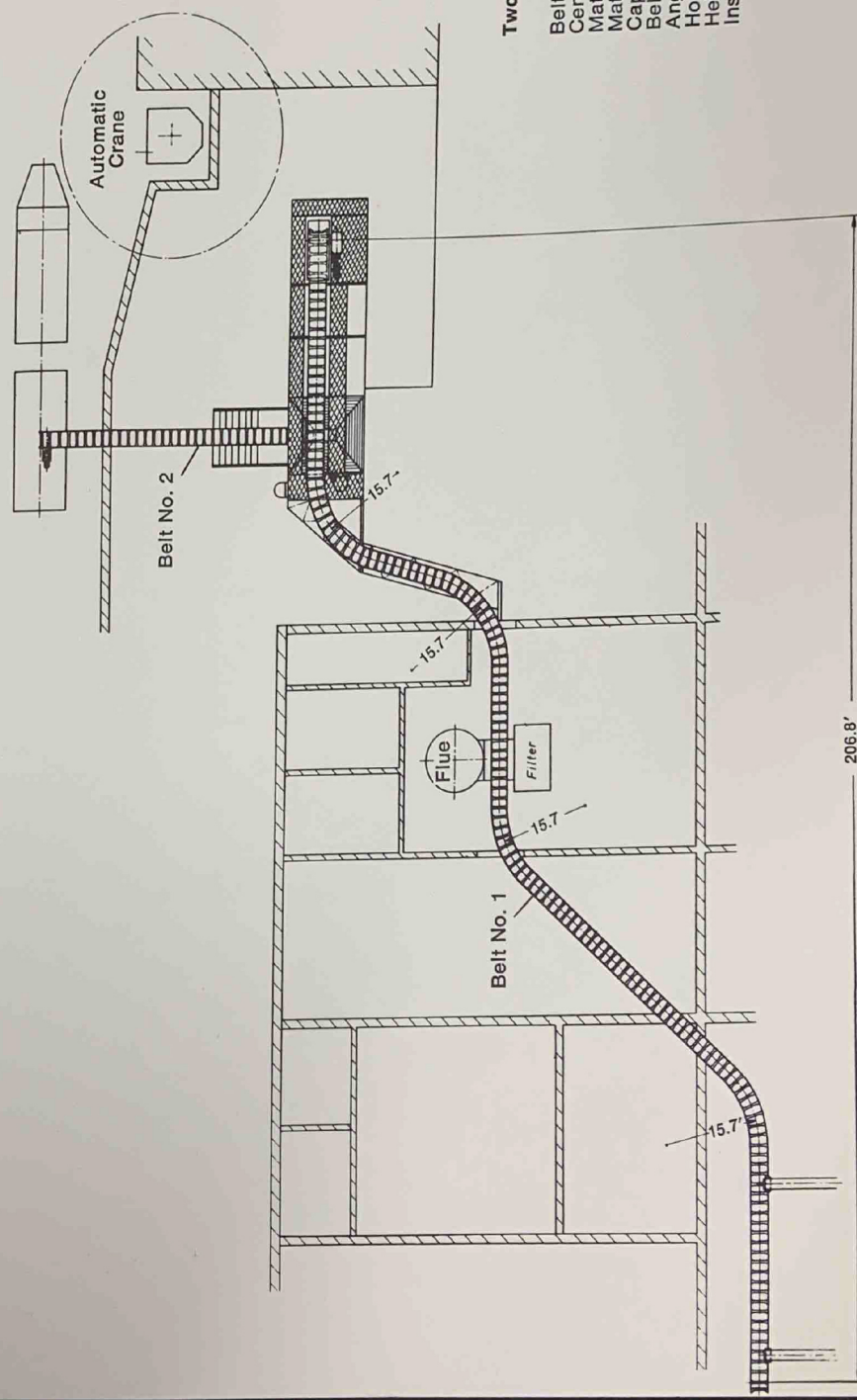

Automatic Crane

Belt No. 2

Belt No. 1

Flue

Filter

206.8'

Two Conveyors in a Power Plant

	Conveyor #1	Conveyor #2
Belt Width:	26"	26"
Center Distance:	209'	58'
Material Transported:	Ashes	Ashes
Material Size:	— 0.8"	— 0.8"
Capacity:	55 TPH	55 TPH
Belt Speed:	158 FPM	158 FPM
Angle of Incline:	13°	32°
Horsepower:	15	5
Height Elevated:	41'	25'
Installed:	July 1963	July 1963

SERPENTIX CONVEYOR CORPORATION

1550 South Pearl Street
Denver, Colorado 80210
Telephone: 303/744-3507